

PS-48-12 Power Supply



The PS-48-12 Power Supply consists of a 48 VDC power supply with PFC and parallel function and one North American standard power cord.

- Input Voltage: 88~264 VAC; 47~63 Hz
- Output Voltage: 48 VDC
- Maximum Output Current: 12.5 A
- Dimensions: 185 x 120 x 93 mm
- Power cords for the UK, EU, and Italy can be purchased separately.
- When ordered in conjunction with TE Technology coolers and temperature controllers the interconnection cables are included free of charge.
- See additional pages for base power supply specifications.



Expert Engineering, Precision Manufacturing:
Quality Thermal Solutions Delivered

<https://tetech.com/> • cool@tetech.com • 231-929-3966 • 1590 Keane Drive • Traverse City, MI 49696



- Features :
 - Universal AC input / Full range
 - Built-in active PFC function
 - Protections: Short circuit / Overload / Over voltage / Over temperature
 - Forced air cooling by built-in DC fan
 - With DC OK Signal output
 - Current sharing up to 2400W(3+1)
 - Built-in remote ON-OFF control
 - Built-in remote sense function
 - Fixed switching frequency at PFC:88KHz PWM:100KHz
 - Operating altitude up to 3000 meters (Note.6)



■ GTIN CODE

MW Search: <https://www.meanwell.com/serviceGTIN.aspx>



SPECIFICATION

MODEL		PSP-600-48							
OUTPUT	DC VOLTAGE	48V							
	RATED CURRENT	12.5A							
	CURRENT RANGE	0 ~ 12.5A							
	RATED POWER	600W							
	RIPPLE & NOISE (max.) Note.2	300mVp-p							
	VOLTAGE ADJ. RANGE	41 ~ 56V							
	VOLTAGE TOLERANCE Note.3	±1.0%							
	LINE REGULATION	±0.5%							
	LOAD REGULATION	±0.5%							
	SETUP, RISE TIME	1500ms, 50ms at full load							
HOLD UP TIME (Typ.)	20ms at full load								
INPUT	VOLTAGE RANGE Note.5	88 ~ 264VAC	124 ~ 370VDC						
	FREQUENCY RANGE	47 ~ 63Hz							
	POWER FACTOR (Typ.)	0.95/230VAC	0.99/115VAC at full load						
	EFFICIENCY(Typ.)	87%							
	AC CURRENT (Typ.)	6.8A/115VAC	3.4A/230VAC						
	INRUSH CURRENT (Typ.)	20A/115VAC	40A/230VAC						
LEAKAGE CURRENT	<1.3mA/240VAC								
PROTECTION	OVERLOAD	105 ~ 135% rated output power							
		Protection type : Constant current limiting, recovers automatically after fault condition is removed							
	OVER VOLTAGE	57.6 ~ 67.2V							
	Protection type : Shut down o/p voltage, re-power on to recover								
OVER TEMPERATURE	Shut down o/p voltage, re-power on to recover								
FUNCTION	REMOTE CONTROL	RC+/RC-: Short = power on ; Open = power off							
	POK SIGNAL	PSU turn on: 3.3V ~ 5.6V PSU turn off: 0V ~ 1V							
ENVIRONMENT	WORKING TEMP.	-20 ~ +60°C (Refer to "Derating Curve")							
	WORKING HUMIDITY	20 ~ 90% RH non-condensing							
	STORAGE TEMP., HUMIDITY	-40 ~ +85°C, 10 ~ 95% RH non-condensing							
	TEMP. COEFFICIENT	±0.03%/°C (0 ~ 50°C)							
	VIBRATION	10 ~ 500Hz, 2G 10min./1cycle, period for 60min. each along X, Y, Z axes							
SAFETY & EMC (Note 4)	SAFETY STANDARDS	UL62368-1, TUV BS EN/EN62368-1, CCC GB4943.1, BSMI CNS15598-1, AS/NZS62368.1, EAC TP TC 004 approved							
	WITHSTAND VOLTAGE	I/P-O/P:3KVAC	I/P-FG:2KVAC	O/P-FG:0.5KVAC					
	ISOLATION RESISTANCE	I/P-O/P, I/P-FG, O/P-FG:100M Ohms / 500VDC / 25°C/ 70% RH							
	EMC EMISSION	Compliance to BS EN/EN55032 (CISPR32) Class B, BS EN/EN61000-3-2,-3, GB9245, GB17625.1, BSMI CNS15936, EAC TP TC 020							
EMC IMMUNITY	Compliance to BS EN/EN61000-4-2,3,4,5,6,8,11, BS EN/EN55035, light industry level, EAC TP TC 020								
OTHERS	MTBF	1132.9K hrs min. Telcordia SR-332 (Bellcore) ; 142.2K hrs min. MIL-HDBK-217F (25°C)							
	DIMENSION	170*120*93mm (L*W*H)							
	PACKING	1.9Kg; 8pcs/15.5Kg/1.00CUFT							
NOTE	1. All parameters NOT specially mentioned are measured at 230VAC input, rated load and 25°C of ambient temperature. 2. Ripple & noise are measured at 20MHz of bandwidth by using a 12" twisted pair-wire terminated with a 0.1uf & 47uf parallel capacitor. 3. Tolerance : includes set up tolerance, line regulation and load regulation. 4. The power supply is considered a component which will be installed into a final equipment. All the EMC tests are been executed by mounting the unit on a 360mm*360mm metal plate with 1mm of thickness. The final equipment must be re-confirmed that it still meets EMC directives. For guidance on how to perform these EMC tests, please refer to "EMI testing of component power supplies." (as available on https://www.meanwell.com/Upload/PDF/EMI_statement_en.pdf) 5. Derating may be needed under low input voltages. Please check the derating curve for more details. 6. The operating altitude is 2000 meters for CCC, 3000 meters for UL,TUV. The ambient temperature derating of 5°C/1000m is needed for operating altitude greater than 2000m (6500ft). ※ Product Liability Disclaimer : For detailed information, please refer to https://www.meanwell.com/serviceDisclaimer.aspx								

Mechanical Specification

(Unit: mm , tolerance $\pm 0.5\text{mm}$)

RS Connector(CN5) : JST B-XH or equivalent

Pin No.	Assignment	Mating Housing	Terminal
1	RS+	JST XHP or equivalent	JST SXH-001T or equivalent
2	RS-		

Terminal Pin No. Assignment

Pin No.	Assignment
1	AC/L
2	AC/N
3	FG \perp
4	P(Current Share)
5	POK
6	R.C.G
7	R.C.
8-11	DC OUTPUT +V
12-15	DC OUTPUT -V

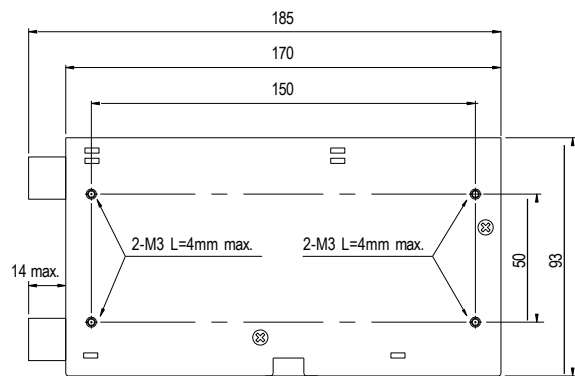
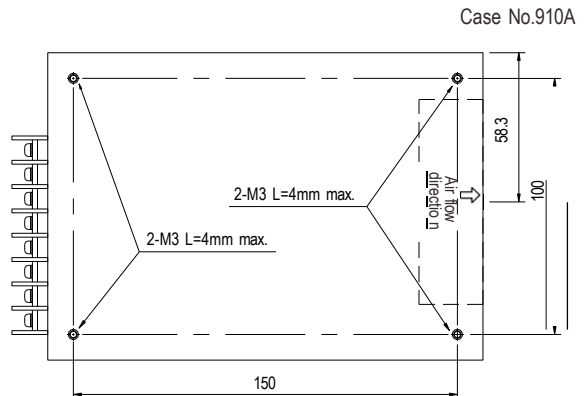
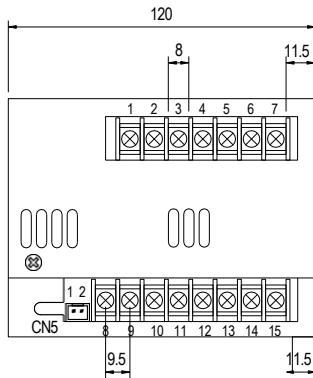

Case No.910A

Block Diagram

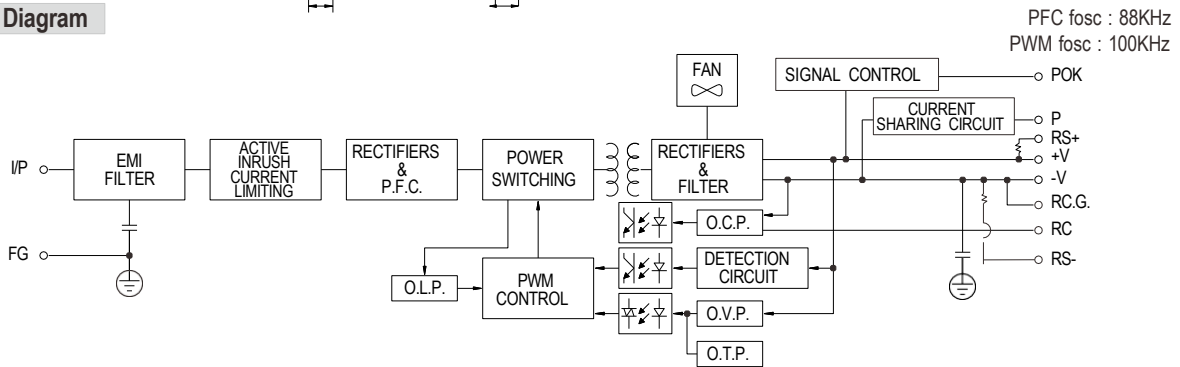

Derating Curve

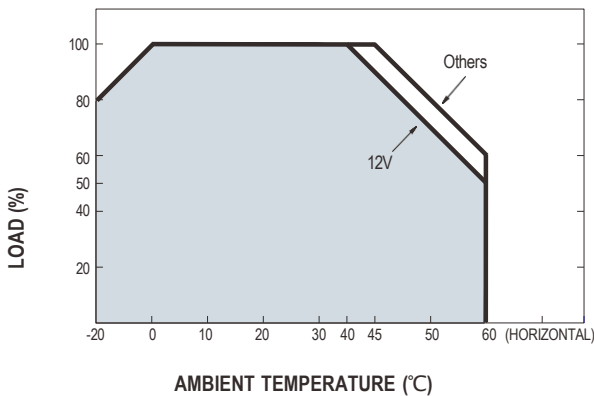

Output Derating VS Input Voltage

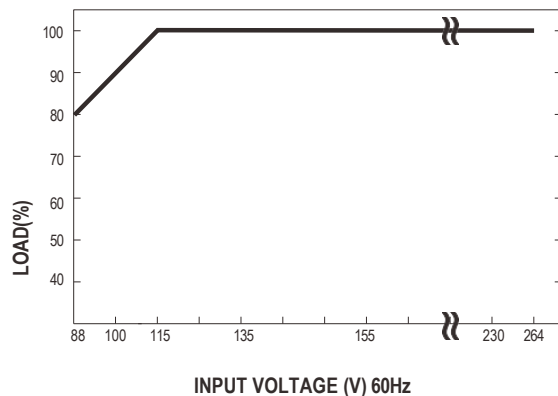

Control Terminal Instruction Manual

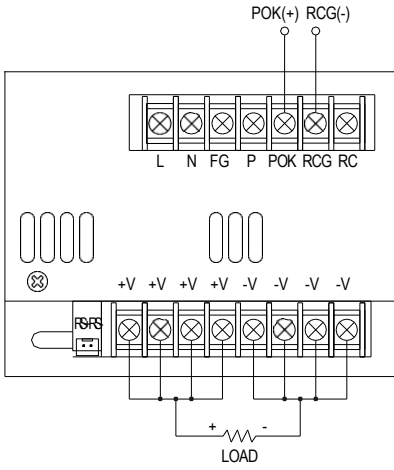

POK Signal

POK Signal is the voltage difference between "RCG" and "POK" pin output POK Signal for TTL level signal
 PSU turn on: 3.3V ~ 5.6V
 PSU turn off: 0V ~ 1V

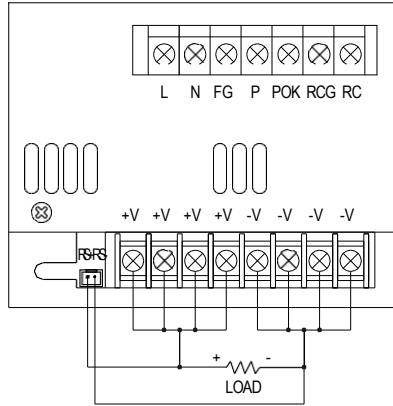

Remote Sensing

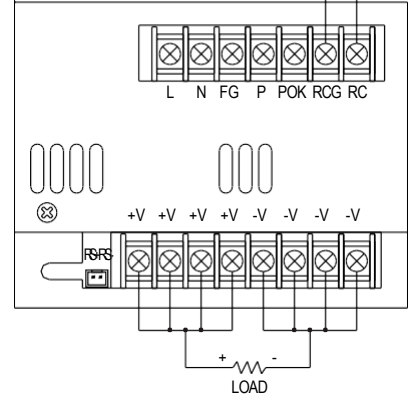

Remote Control

Power ON: RCG and RC for short
 Power OFF: RCG and RC for open

Parallel Operation with Remote Sensing

- (1) Parallel operation is available by connecting the units shown as below (+S,-S and P are connected mutually in parallel) :
- (2) The voltage difference among each output should be minimized that less than 0.2V is required.
- (3) The total output current must not exceed the value determined by the following equation (Output current at parallel operation)

$$=(\text{The rated current per unit}) \times (\text{Number of unit}) \times 0.9.$$
- (4) In parallel operation 4 units is the maximum, please consult the manufacture for other applications.
- (5) When remote sensing is used in parallel operation, the sensing wire must be connected only to the master unit.
- (6) When in parallel operation, the minimum output load should be greater than 3% of total output load.
 (Min. load > 3% rated current per unit x number of unit)

