

MP-4067 Thermistor Temperature Sensor

- NTC Thermistor / temperature sensor for measuring from -20 °C to +100 °C with a 15K ohm resistance at 25 °C; +/-0.1 °C interchangeable tolerance within 0 °C to +70 °C range.
- Sensor can be epoxied into holes for accurate measurements.
- Solid nickel wires have a lower thermal conductivity than copper, reducing influence on temperature measurements.
- Compatible with all TE Technology temperature controllers.

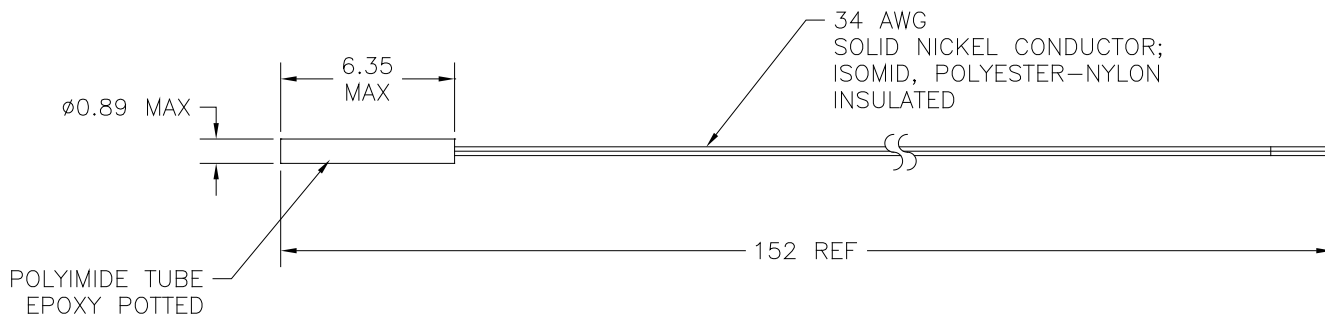

Wire leads may be extended with standard copper wire of any gauge recommended for TE Technology's controllers. Apply appropriate protection to wire bends over sharp edges. All dimensions in mm.

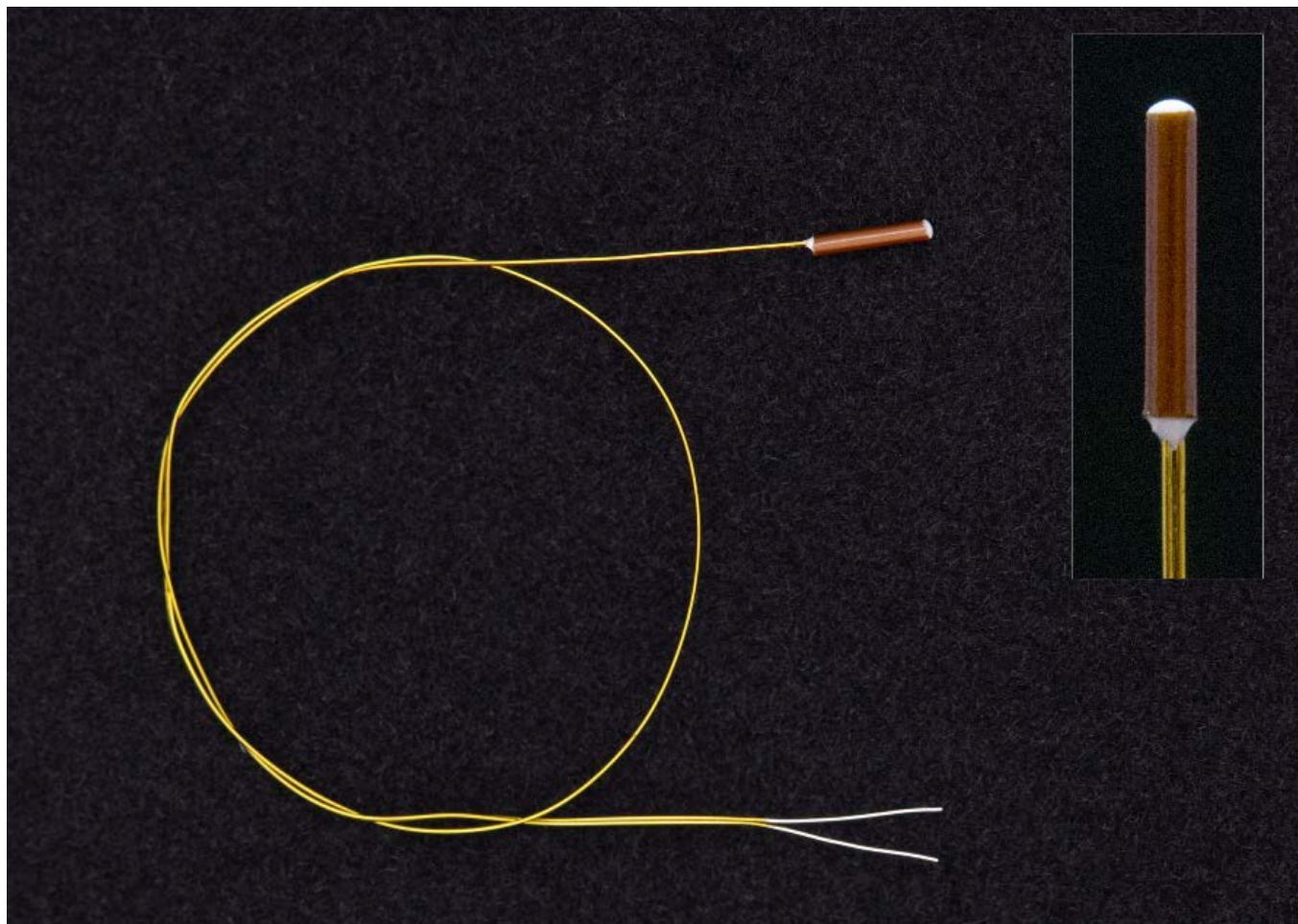

Expert Engineering, Precision Manufacturing:
Quality Thermal Solutions Delivered

<https://tetech.com/> • cool@tetech.com • 231-929-3966 • 1590 Keane Drive • Traverse City, MI 49696

MP-4067 Thermistor Temperature Sensor

Sensor resistance at 25 °C:	15,000±65 Ω
Sensor tolerance between 0 ° to 70 °C:	±0.1 °C
Operating range:	-20 °C to +100 °C
Weight:	0.08 grams

TEMPERATURE, °C	RESISTANCE, OHMS	TEMPERATURE, °C	RESISTANCE, OHMS	TEMPERATURE, °C	RESISTANCE, OHMS
-20	146735	21	17923	61	3590
-19	138447	22	17136	62	3464
-18	130677	23	16388	63	3343
-17	123390	24	15676	64	3227
-16	116554	25	15000	65	3115
-15	110138	26	14356	66	3008
-14	104113	27	13744	67	2905
-13	98454	28	13161	68	2806
-12	93137	29	12606	69	2711
-11	88138	30	12078	70	2620
-10	83438	31	11574	71	2532
-9	79016	32	11095	72	2448
-8	74855	33	10637	73	2367
-7	70938	34	10202	74	2288
-6	67249	35	9786	75	2213
-5	63773	36	9389	76	2141
-4	60498	37	9011	77	2072
-3	57410	38	8650	78	2005
-2	54498	39	8306	79	1940
-1	51750	40	7976	80	1878
0	49157	41	7662	81	1818
1	46709	42	7362	82	1761
2	44397	43	7075	83	1705
3	42213	44	6801	84	1652
4	40150	45	6539	85	1601
5	38199	46	6289	86	1551
6	36354	47	6049	87	1503
7	34608	48	5820	88	1457
8	32957	49	5600	89	1412
9	31394	50	5391	90	1369
10	29914	51	5190	91	1328
11	28512	52	4997	92	1288
12	27183	53	4813	93	1250
13	25925	54	4637	94	1212
14	24731	55	4467	95	1176
15	23600	56	4305	96	1142
16	22526	57	4150	97	1108
17	21508	58	4001	98	1076
18	20541	59	3858	99	1045
19	19623	60	3721	100	1014
20	18751				

Please review the product manual: [Thermoelectric Temperature Controller Sensor Attachment with Notes on Thermocouples](#), FAQ's and related technical information, and ordering information posted on our web site before purchasing or using this product. When used in conjunction with a Peltier-Thermoelectric Cooler Assembly or Module, please review the [Thermoelectric Cooling Assembly \(TCA\) Instruction Manual](#) or [TEM \(Thermoelectric Module\) Mounting Procedure](#). When used in conjunction with a temperature controller, please review the temperature controller manual. These manuals contain general information, guidelines, and precautions for thermoelectric cooling and control applications.

FINAL DETERMINATION OF THE SUITABILITY OF THE PRODUCT IS THE SOLE RESPONSIBILITY OF THE USER. TE TECHNOLOGY MAKES NO WARRANTY, REPRESENTATION OR GUARANTEE REGARDING THE SUITABILITY, NOR DOES TE TECHNOLOGY ASSUME ANY LIABILITY RESULTING FROM USE AND SPECIFICALLY DISCLAIMS ANY AND ALL LIABILITY, INCLUDING WITHOUT LIMITATION CONSEQUENTIAL OR INCIDENTAL DAMAGES.



Expert Engineering, Precision Manufacturing:
Quality Thermal Solutions Delivered

<https://tetech.com/> • cool@tetech.com • 231-929-3966 • 1590 Keane Drive • Traverse City, MI 49696